

POINT-HD SET UP MODES

Point-HD Telestrator is very flexible and can be set up in a number of ways for studio or outside broadcast use. The diagrams shown below provide some of the most common configurations, if you require advice on a custom set up not shown below then please do ask by sending an email to info@e-mediavision.com

CHOOSING THE RIGHT SET UP

Choosing the correct set up mode for the POINT-HD Telestrator depends upon a number of factors such as:

- Is the production in a studio or outside broadcast event (on Location) such as a sports stadium?

For outside broadcast events, it may be easier to locate the POINT-HD workstation and the presenters touch screen at the commentary position. In this case you will need to provide 3 or 4 video cables between the production truck and the commentary position.

The video cables / signals required to interface with the POINT-HD include:

- 1 x Video Input (SD/HD-SDI) Clean Feed from Vision Switcher
- 1 x Video KEY (SD/HD-SDI) out from Point to Mixers DSK input
- 1 x Video FILL (SD/HD-SDI) out from Point to Mixers DSK input
- 1 x Video External reference (Genlock) input to Point.

Note: The Point-HD can be locked to the incoming SDI source, this would eliminate the need for an external reference source cable, and alternatively you can feed the Key & Fill outputs via two external frame synchronizers into the DSK.

- If the cable distance between the commentary position and the production truck is less than 300 meters (980 feet) then you can locate the Point-HD workstation inside the truck and extend out the touch screen using CAT5 cable and a pair of KVMs that support RS232 serial port. You can also extend to greater distances using fiber optic based KVMs and fiber optic cable, typically this allows the touch screen to be remotely located to around 10KM (6 Miles)
- For studio and fixed installations, the POINT-HD workstation can be located either in the production gallery or in the technical engineering racks. The touch screen control can be extended using CAT5 cabling and KVMs to production gallery and studio presenters locations.

POINT-HD BASIC SETUP 1

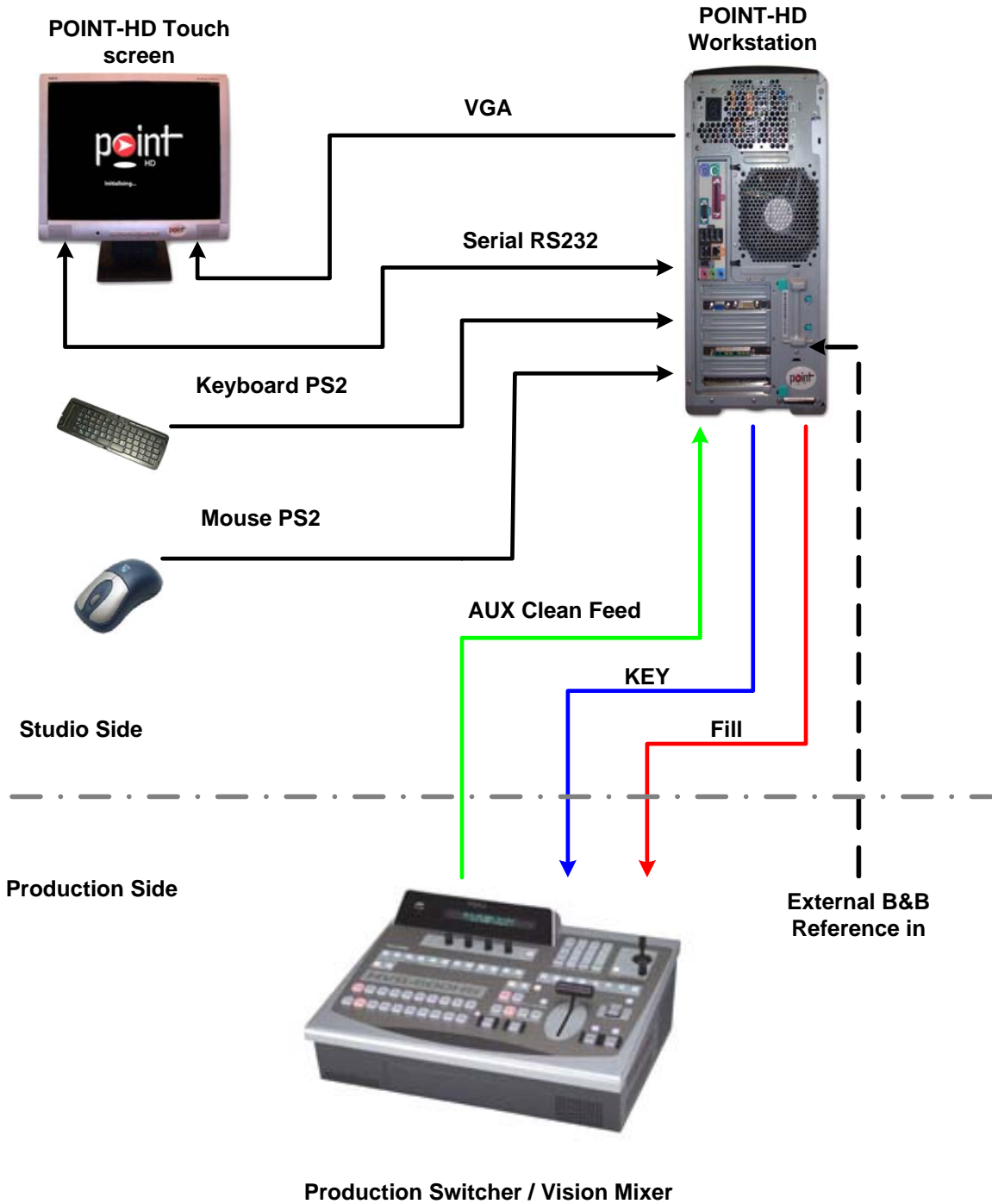

POINT-HD BASIC SETUP WITH KVM EXTENDER

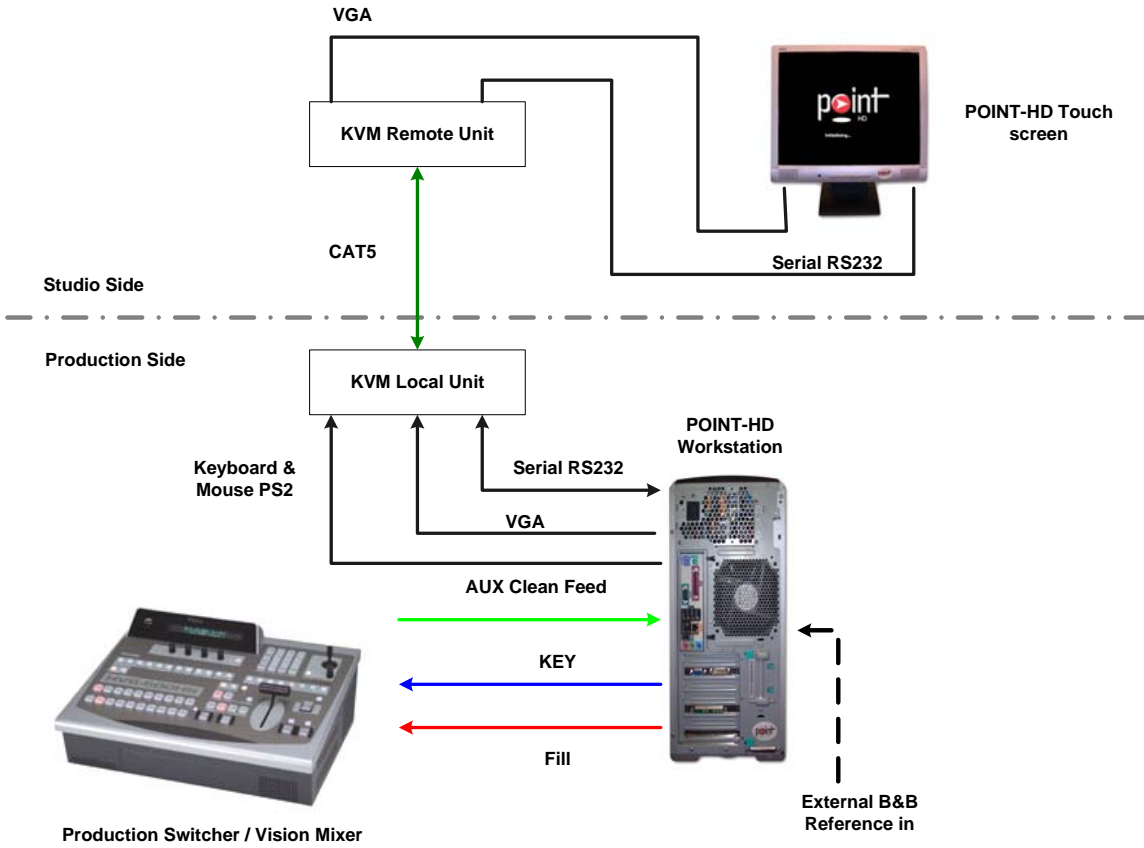

POINT-HD BASIC SETUP WITH GALLERY CONTROL

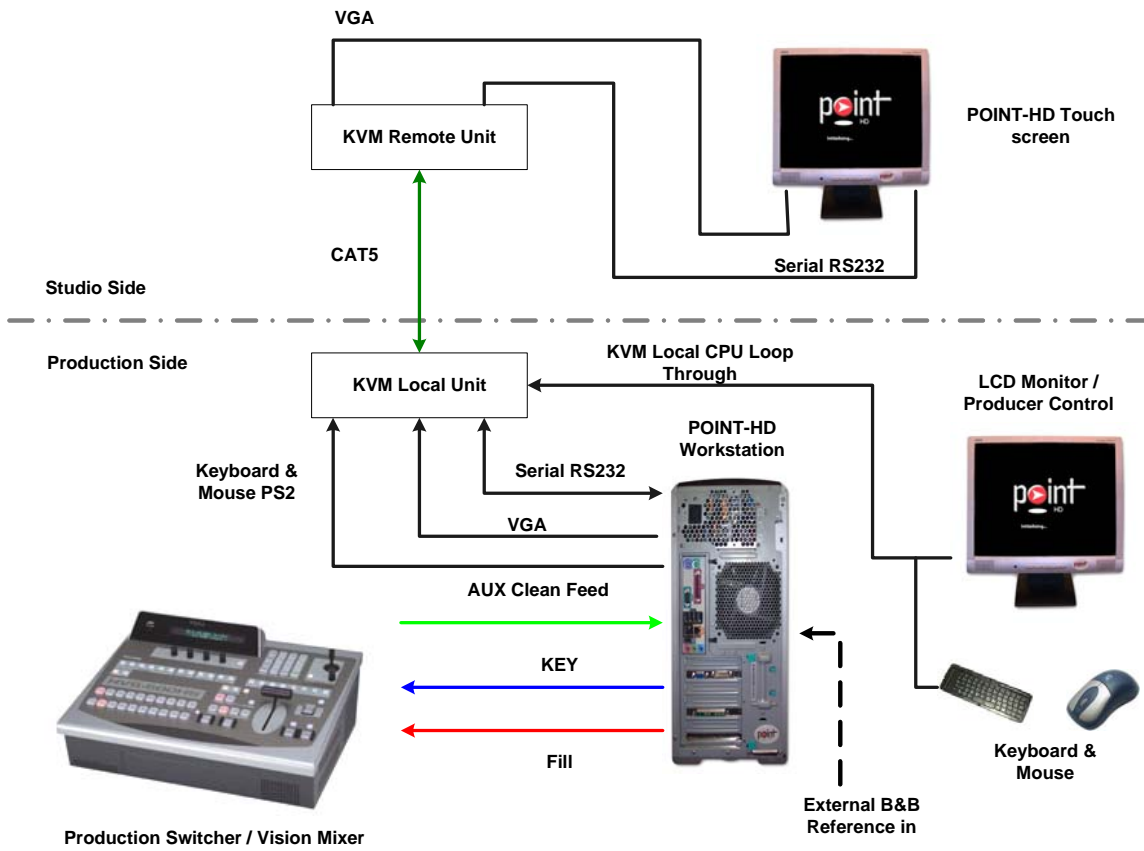

POINT-HD DUAL SCREEN SETUP

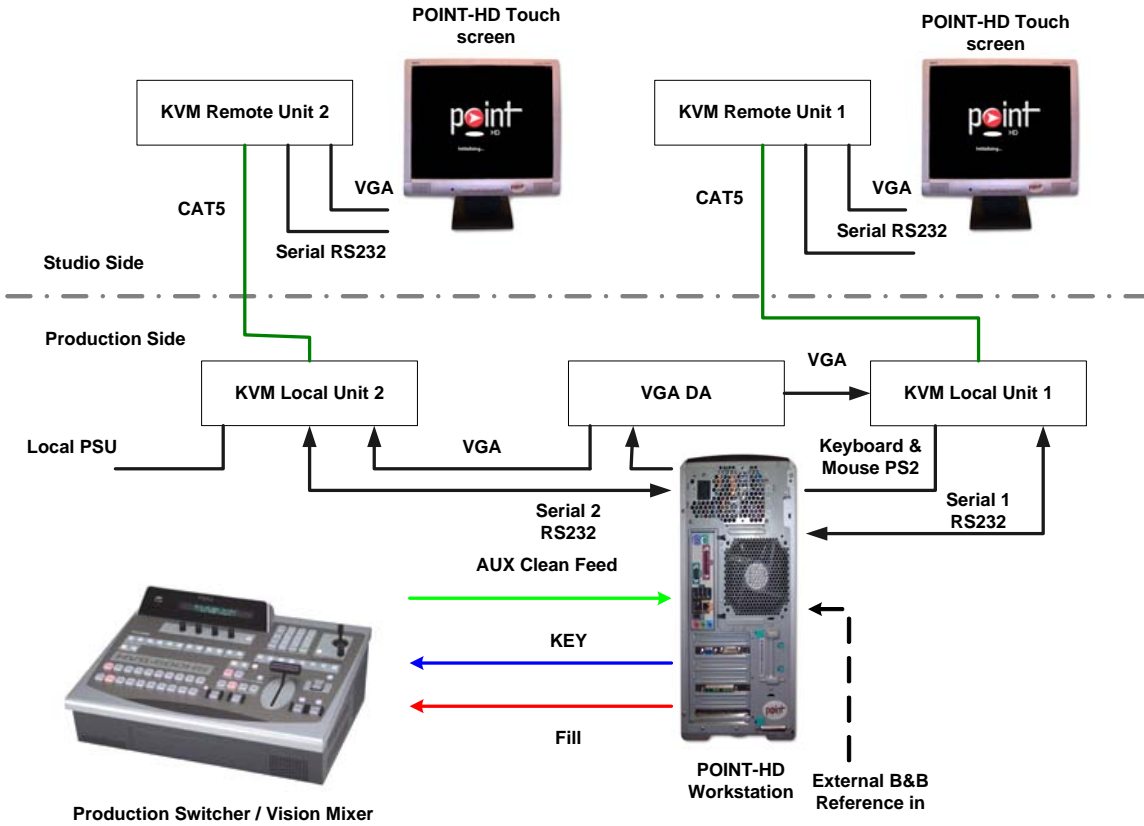

POINT-HD DUAL SCREEN WITH GALLERY CONTROL

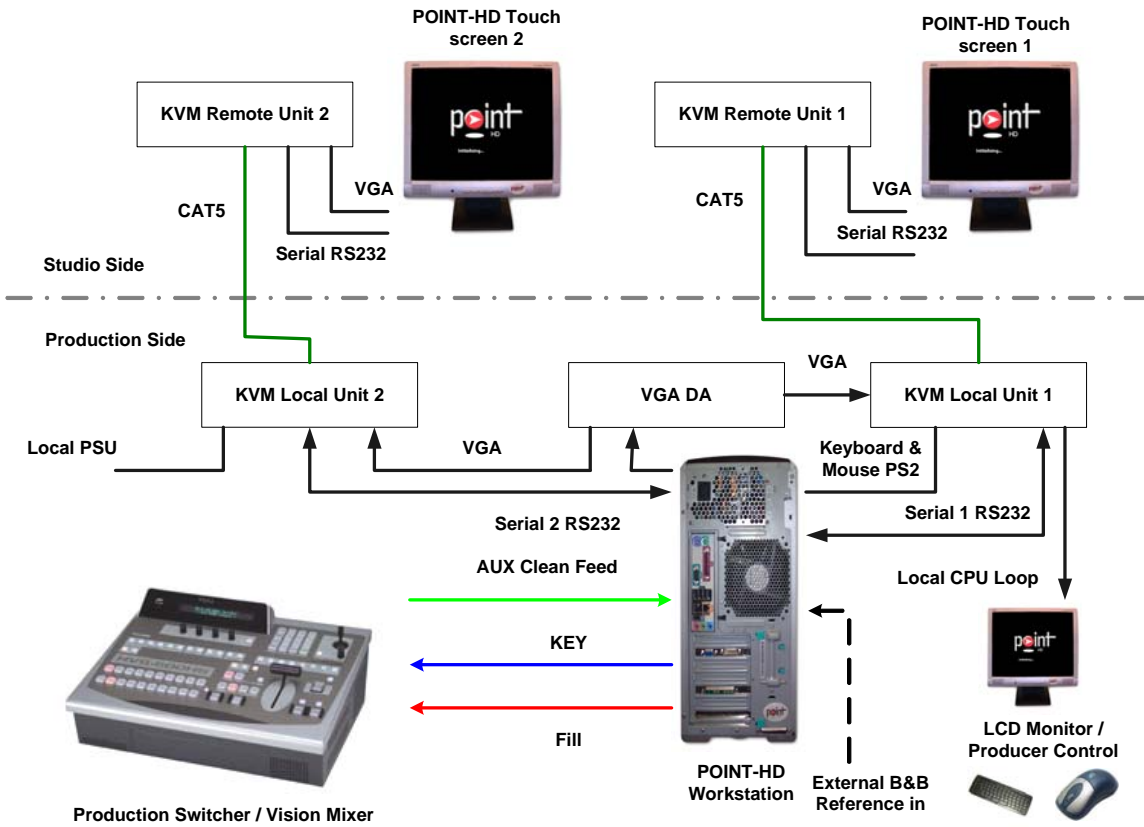

POINT-HD 3 SCREEN SETUP

